

# SKYLINK

## QUICK START GUIDE

**PLEASE READ BEFORE DEPLOYMENT**



Blue Sky Network 

# SKYLINK DUAL-MODE DATA GATEWAY

---

## Top Panel:



## Bottom Panel:



- |                               |                      |
|-------------------------------|----------------------|
| 1. Iridium antenna connector  | 4. Cellular antenna  |
| 2. Power LED light            | 5. Power port        |
| 3. Cellular antenna connector | 6. Connectivity port |

# HARDWARE SETUP

## STEP 1: INSTALL THE SIM CARDS

**NOTE:** If you purchased the Dual-Mode Data Gateway directly from Blue Sky Network, it will arrive with the cellular and Iridium® SIM cards already installed.

Obtain an Iridium SIM card and a cellular SIM card. Un-screw the two Phillips screws that secure the entire bottom panel and carefully remove the panel. Take care not to damage the cable wires.

Insert the Iridium and cellular SIM cards in the slots behind the connectivity port (the Iridium SIM slot is the larger of the two slots). Re-attach the bottom panel and tighten the screws, taking care not to damage the cable wires.

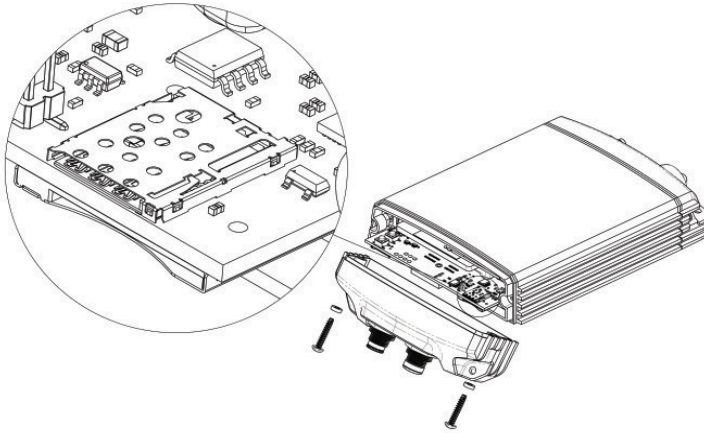

## STEP 2: ATTACH THE ANTENNAS

Screw the cellular antenna to the cellular antenna connector on the Data Gateway. Screw the Iridium antenna, or the Iridium antenna cable connector, to the Iridium antenna connector on the Data Gateway. The Blue Sky Network Iridium antenna may be one of three antennas:

1. Direct connection MARUWA black plastic antenna (MHL-1621C)
2. High-profile white Maxtena conical antenna with cable (M1621HCT-HP)
3. High-profile white SCAN conical antenna with cable (65020-000)

### STEP 3: CONNECT THE POWER

Connect one end of the power cable to the power port on the Data Gateway and connect the other end to a power source. The power cable may be any of these options:

1. 12VDC Cigarette lighter adapter
2. 12VDC Power adapter with Ignition Sense
3. POE injector (self-assembly kit included)
4. AC/DC Power supply (self-assembly kit included)

**NOTE:** There are two Ethernet ports on the POE injector adapter. Ensure you use the Data+Power port.

### STEP 4: INSTALL THE DEVICE

**NOTE:** Personnel should maintain a safe distance of 30cm. (11.8 in.) minimum from the antenna while the terminal is operating to avoid exposure.

To ensure proper terminal and antenna functioning, securely fasten the unit to the rigid object. The antenna should be mounted with an unobstructed, clear view of the sky, as far away from other antennas as possible, and in an area that prevents exposure to its radiation.

See the **SkyLink Installation Guide** for more antenna and device requirements

## IMPORTANT!

Ensure SkyLink is installed with the satellite antenna pointing skyward and there is a maximum of 8.2° obstruction from ground-based obstacles. Especially obstacles on the North/South axis.



# SOFTWARE SETUP

## STEP 1: ACTIVATE SERVICE

Navigate to <https://blueskynetwork.com/contact/activate-service> and submit an activation request.

## STEP 2: CONNECT TO THE DATA GATEWAY

A label on the box and the back of the device shows the Wi-Fi QR code, SSID, and password. If using a smart device, connect to the Data Gateway Wi-Fi by scanning the QR code. Alternatively, connect using the Wi-Fi SSID and password.

Open a web browser and type 192.168.111.1 into the address bar, then press enter. The SkyLink Web Interface (WI) will appear.

Default username and password: admin

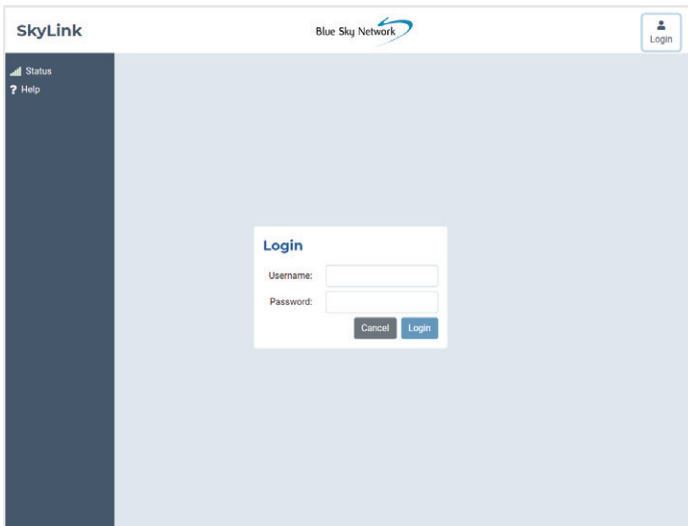

## STEP 3: ENABLE BASIC SETTINGS

In the SkyLink WI, navigate to the following screens to make these standard device configurations. Remember to press 'Save' on each screen after making changes.

## Status

- System Information > Location > Ensure device shows an accurate GPS location
- Satellite > Ensure device has signal
- Cellular > Ensure device has signal

## Firewall

- Firewall Profile > Unrestricted, or set to preference

## General Settings

- SkyLink > Data Routing: Cellular then Satellite
- Satellite > Satellite Enabled: ON
- Satellite > Data Enabled: ON
- Cellular > Enter GSM SIM APN setting for your network provider

The screenshot displays the SkyLink configuration interface. At the top, it shows the 'SkyLink' logo and 'Blue Sky Network' branding. A navigation sidebar on the left includes options like Status, General Settings, Network, Firewall, Calls, Voice Extensions, Advanced, Remote Management, Diagnostics, and Help. The main content area is divided into several sections:

- SkyLink:** Includes fields for Asset Tag (BSN-1337-42B), Max Daily Usage, Data Routing (set to Cellular then Satellite), and Serial Port (toggled ON). A 'Change Password' button is also present.
- Satellite:** Features 'Satellite Enabled' and 'Data Enabled' toggle switches, both of which are turned ON.
- WiFi:** Shows 'WiFi' as turned ON. Fields include SSID (Skylink-c89c), Mode (2.4 GHz), Channel (Auto), Security (WPA2-PSK), and Password. A QR code is displayed with the text 'Scan to Connect' below it.
- Cellular:** Shows 'Cellular' as turned ON. Fields include APN (em), Username (Optional), Password (Optional), IMEI (861364040178400), SIM (89883030000052347330), and Network (T-Mobile).

At the bottom of the interface, there are buttons for 'Reboot', 'Cancel', and 'Save'.

After configuring the above settings on each screen, press 'Save' and then 'Reboot' on the General Settings screen to apply the changes. Please refer to the **SkyLink User Guide** for a comprehensive list of the configurations that can be made on each screen as well as the device capabilities.

## STEP 4: CONNECT TO THE ONLINE PORTAL

To remotely manage a fleet of devices, use the SkyLink Online Portal. In a web browser type <https://portal.skylinknet/login> into the address bar, press enter, then sign in to your account.

**NOTE:** Resellers will receive their login information from their account manager. Customers will receive it from the BSN operations team.

### Basic Settings & Configurations

Click the wheel icon in the top right of the screen to view and update your account settings. Navigate to the **My Org** screen to edit your organization's contact info and see details about your parent org.

The **Profiles** screen allows you to create device & voice profiles that can be saved as configuration templates and applied to groups of units. Click 'New' and complete all mandatory fields to add a General Settings, Network, and Firewall profile or to configure a SIP or POTS extension.

Use the **Devices** screen to apply device & voice profiles and assign a unit to an organization. Select the device(s), make the desired configurations, then press 'Ok' or 'Assign' to apply the changes.

Manage users throughout the system, including their contact info, on the **Users** screen. When creating a new user, they will receive an email to change their password. They will then be sent a verification ID to finish account setup.

See the **SkyLink Cloud Services Guide** for more information on Portal capabilities.



SkyLink User, Installation and Cloud Services Guides can be viewed and downloaded from this location:

<https://support.blueskynetwork.com/download-resources>



Questions? Contact us at [support@blueskynetwork.com](mailto:support@blueskynetwork.com)  
+ 1 858-551-3894

# Blue Sky Network

---



[www.blueskynetwork.com](http://www.blueskynetwork.com)

SKYLINK-QUICK-START-GUIDE-V2.0

For customer use only. Not intended for further distribution.